

# Integrally Heated Sprue Bushings

**Reliable,  
High Performance  
Direct-Gating**



# D-M-E

## Integrally Heated Sprue Bushings

### .750" SERIES

### NEW Patented Design!

The **Integrally Heated Sprue Bushing** is uniquely designed for high performance and reliability for direct gating applications, even with the most demanding molding cycles and plastic resins.

The product's advanced heat transfer capability is attributed to its integrally heated design, resulting in a more uniform heat profile. A replaceable thermocouple is strategically located near the melt flow channel to optimize processing conditions with all thermoplastics.

#### FEATURES & BENEFITS:

- **Distributed watt density...**  
maintains a more uniform heat profile.
- **High refractory insulation...**  
provides superior heat transfer.
- **Streamlined flow channel...**  
minimizes pressure loss.
- **Fully sealed construction...**  
maintains highest product reliability.
- **High-grade alloy steel construction...**  
increases durability and longer life.
- **Replaceable thermocouple...**  
allows for Type "J" or "K".

#### Tip Styles & Flow Diagrams

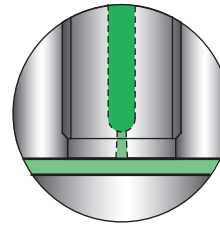

Sprue Tip

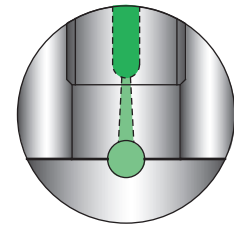

Extra Stock Sprue Tip

#### Direct Gating Diagram

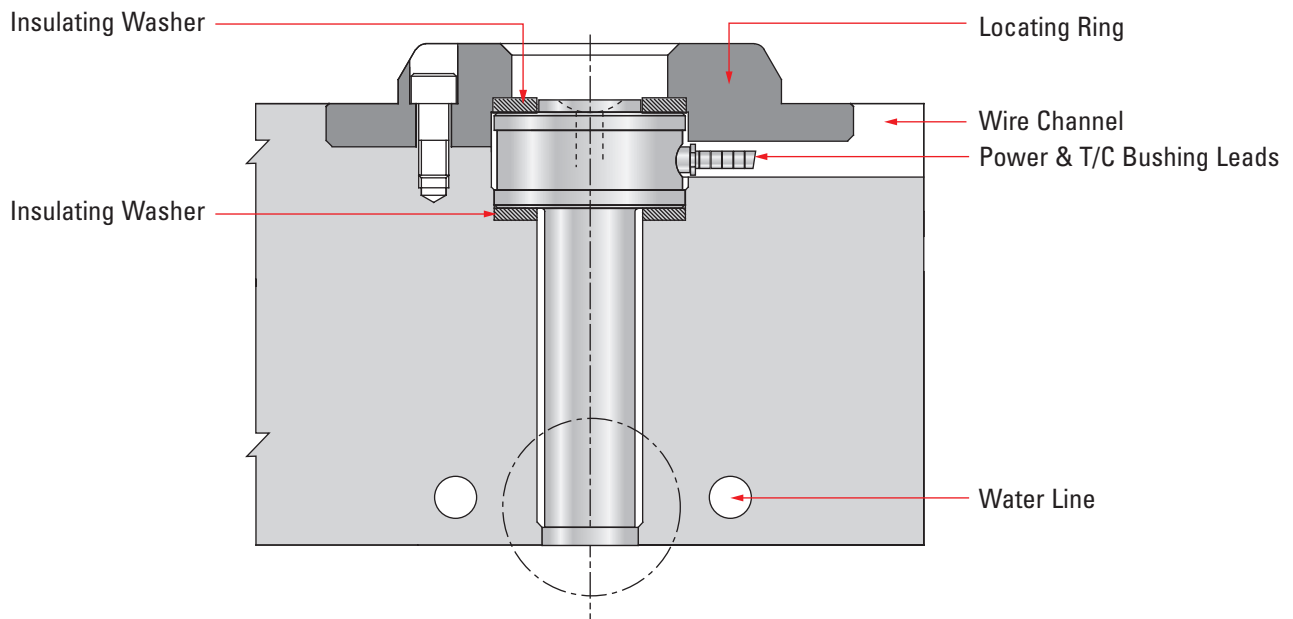

# Integrally Heated Sprue Bushings

## .750" SERIES USER GUIDE

### Integrally Heated Sprue Bushings

The D-M-E Integrally Heated Sprue Bushing is an exclusive medium volume bushing with the ability to process a wide range of resins. Its streamlined flow channel terminates in a reverse taper gate, providing minimal pressure loss and allowing for rapid gate freeze. The formation of a small gate stub on the part or runner results in a machine hold-time reduction, with no increase in sink marks on the part.

The Sprue Bushing's superior heat transfer capacity is attributed to its integrally heated design. To optimize processing conditions for all thermoplastics, a replaceable thermocouple is strategically located near the flow channel.

The Integrally Heated Sprue Bushing has a .187" flow diameter, and is offered in two head styles and two gate styles to suit a broad range of applications.



### Gating Options for Sprue Bushings

#### Sprue Gate

Suitable for most applications, the Sprue Gate is provided as standard on the Heated Sprue Bushing. **(Please note that this gate style is not intended for machining.)** The press fit areas are held to  $\pm .0005"$ .

#### Extra Stock Sprue Gate

The Extra Stock Sprue Gate is available for applications requiring machining of the gate area for runner profiles, part contours, or adjustment of the bushing height. The .750" diameter bushing has .500" of extra stock. The press fit areas are held to  $\pm .0005"$ .

### Head Options for Sprue Bushings

#### .500" Radius\*

Provided with a 0.500" radius to mate with 0.500" radius machine nozzles. Reinforced contact area for improved strength and heat transfer.

#### .750" Radius\*

Provided with a 0.750" radius to mate with 0.750" radius machine nozzles. Reinforced contact area for improved strength and heat transfer.

**\*Other radii are available by special request.**



GATING OPTIONS	GATE DIAMETERS
Sprue	.080" to .125"* max. (2mm to 3.2mm* max.)
Extra Stock Sprue	.080" to .125"* max. (2mm to 3.2mm* max.)

\* Re-machine gate diameter, if necessary, for larger shot weights. Maintain gate angle and remove all machine marks.

#### .750" Series Maximum Shot Weights (0.080" Gate)

GATING OPTIONS	RESIN VISCOSITY		
	HIGH	MEDIUM	LOW
Sprue	50g	150g	300g
Extra Stock Sprue	50g	150g	300g

Contact D-M-E when exceeding minimum shot weight.

#### .750" Series Resin Compatibility

GATING OPTIONS	COMMODITY RESIN	ENGINEERING RESIN	GLASS-FILLED RESIN
Sprue	⚡	⚡	⚡
Extra Stock Sprue	⚡	⚡	⚡

⚡ = Recommended

Reference: High Viscosity = Melt Flow (0.02 – 6); Medium Viscosity = Melt Flow (7 – 15); Low Viscosity = Melt Flow (16 – up). The values expressed in grams are for reference purposes only. Part dimensions, wall thickness, mold condition, and molding parameters must also be considered.

# D-M-E Integrally Heated Sprue Bushings .750" SERIES

## Head Options

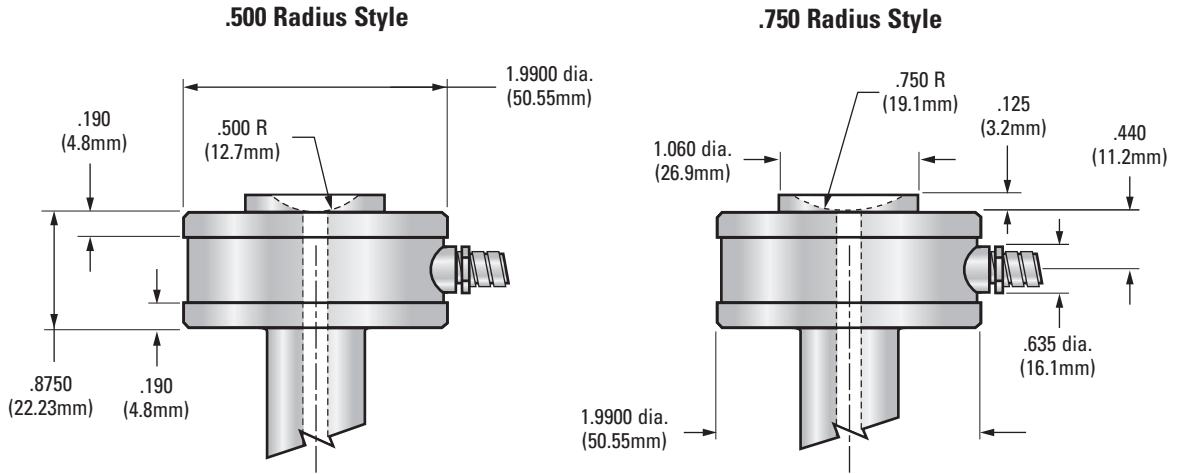

## Gating Options / Bushing Dimensions

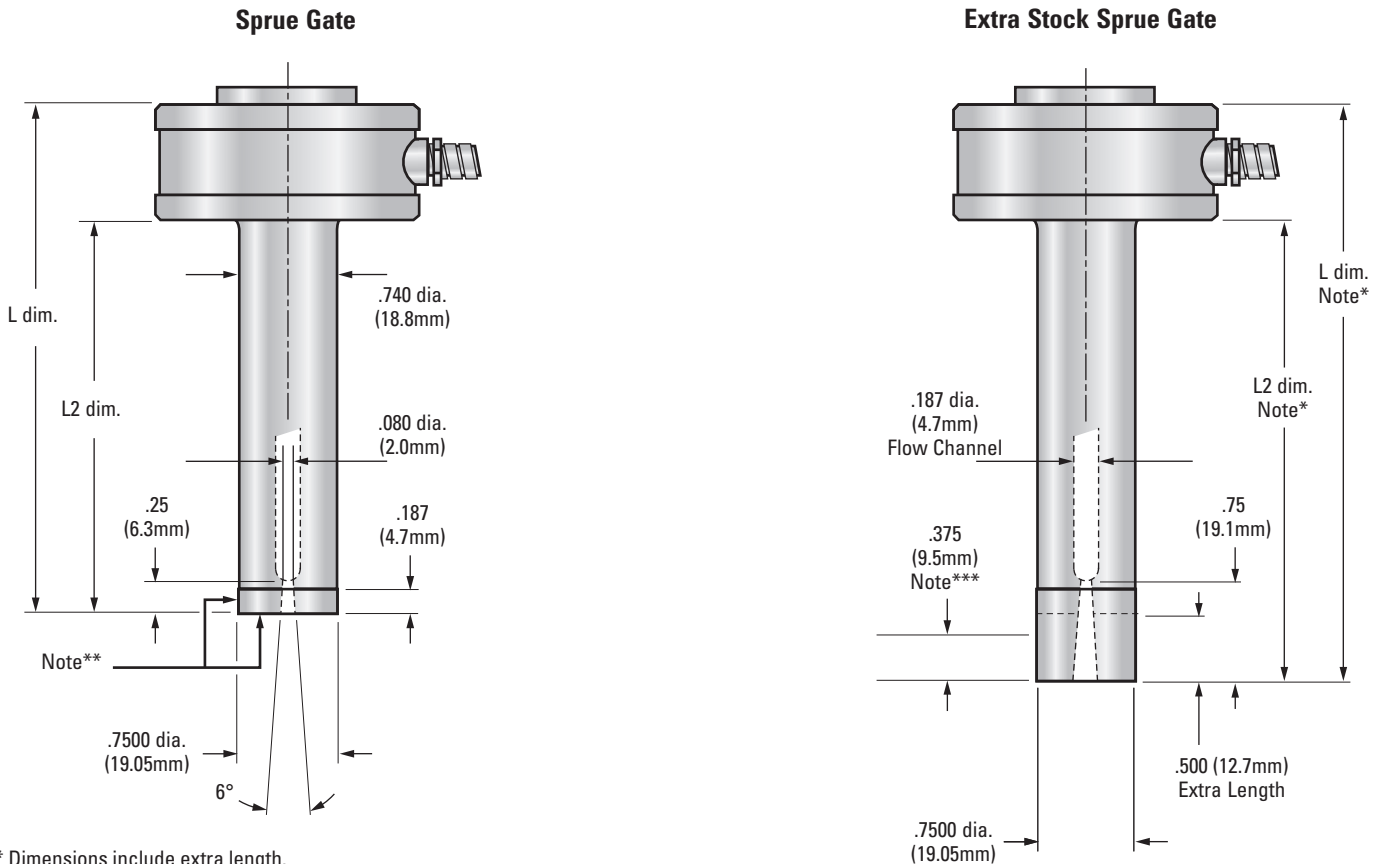



\* Dimensions include extra length.  
 \*\* This surface cannot be machined, modified or altered.  
 \*\*\* Maximum machining stock; only this area can be machined.

Dimensions are in inches; millimeters are in parentheses.  
 Note: For additional gate dimensions see page 3

# Integrally Heated Sprue Bushings

## .750" SERIES SPECIFICATIONS

GATE STYLE	L DIM.		L2 DIM.		.500 RADIUS HEAD	.750 RADIUS HEAD	WATTS	THERMOCOUPLE
	2.375"	(60.3)	1.500"	(38.1)	SB031000	SB031001	315	MT020020
	2.875"	(73.0)	2.000"	(50.8)	SB031008	SB031009	370	MT020020
	3.375"	(85.7)	2.500"	(63.5)	SB031016	SB031017	425	MT020020
	3.875"	(98.4)	3.000"	(76.2)	SB031024	SB031025	480	MT020020
	4.375"	(111.1)	3.500"	(88.9)	SB031032	SB031033	535	MT020021

GATE STYLE	L DIM.		L2 DIM.		.500 RADIUS HEAD	.750 RADIUS HEAD	WATTS	THERMOCOUPLE
	2.875"	(73.0)	2.000"	(50.8)	SB031004	SB031005	315	MT020020
	3.375"	(85.7)	2.500"	(63.5)	SB031012	SB031013	370	MT020020
	3.875"	(98.4)	3.000"	(76.2)	SB031020	SB031021	425	MT020020
	4.375"	(111.1)	3.500"	(88.9)	SB031028	SB031029	480	MT020020
	4.875"	(123.8)	4.000"	(101.6)	SB031036	SB031037	535	MT020021

All specifications are subject to change without notification.  
Dimensions are in inches; millimeters are in parentheses.

### Right (Standard)\*

\* Standard Lead exit –  
60" (1.52m) wrapped - 600 volt leads;  
right angle lead exit; and 6" (15.2cm)  
stainless steel, square-lock armored cable.

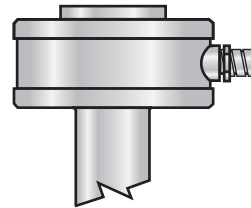

#### ITEM NUMBER

CKPTIC-1



### Mold Power-Thermocouple Input Connector

A Single-Zone Power-Thermocouple Input Connector is available for mounting in or on the mold to accept the power-thermocouple cable from the mainframe. The water-resistant connector has an integral retaining latch for a secure cable connection and numbered screw-type terminals for power and thermocouple lead wires.

\*Can be mounted on top of mold

### Recommended Mold Pocket Layout For Mold Power-Thermocouple Input Connector (CKPTIC-1)

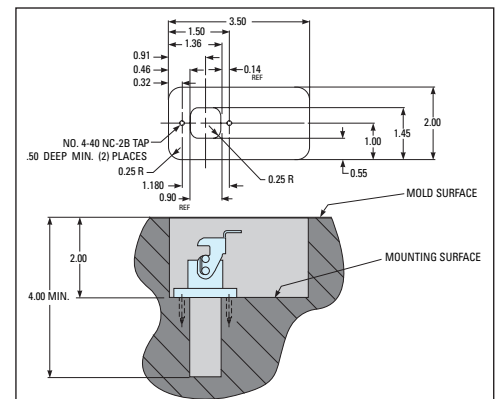

#### ITEM NUMBER

MPTC-10

MPTC-20



### Armored Mold Power-Thermocouple Cables

Single-Zone Mold Power-Thermocouple Cables are constructed of special lead wire for use in high temperature environments, and are available to connect the mainframe to the input connector on the mold. Available in lengths of 10 or 20 feet. Integral retaining latches on the mainframe and mold connections provide secure cable connections. Connector configurations ensure proper insertion of cable.

For complete information on temperature controls, please see D-M-E Control Systems Catalog.

# D-M-E Integrally Heated Sprue Bushings .750" SERIES

## .750" Series Bore & Gate Dimensions

### Insulating Washer Specifications

	TOP	BOTTOM
Item Number	MAX10015	MAX10027
O.D.	1.99 (50.5mm)	1.99 (50.5mm)
I.D.	1.07 (27.2mm)	.810 (20.6mm)
Thickness	.125 (3.2mm)	.125 (3.2mm)

Note: Insulating Washers are not required, but are recommended for high temperature applications.

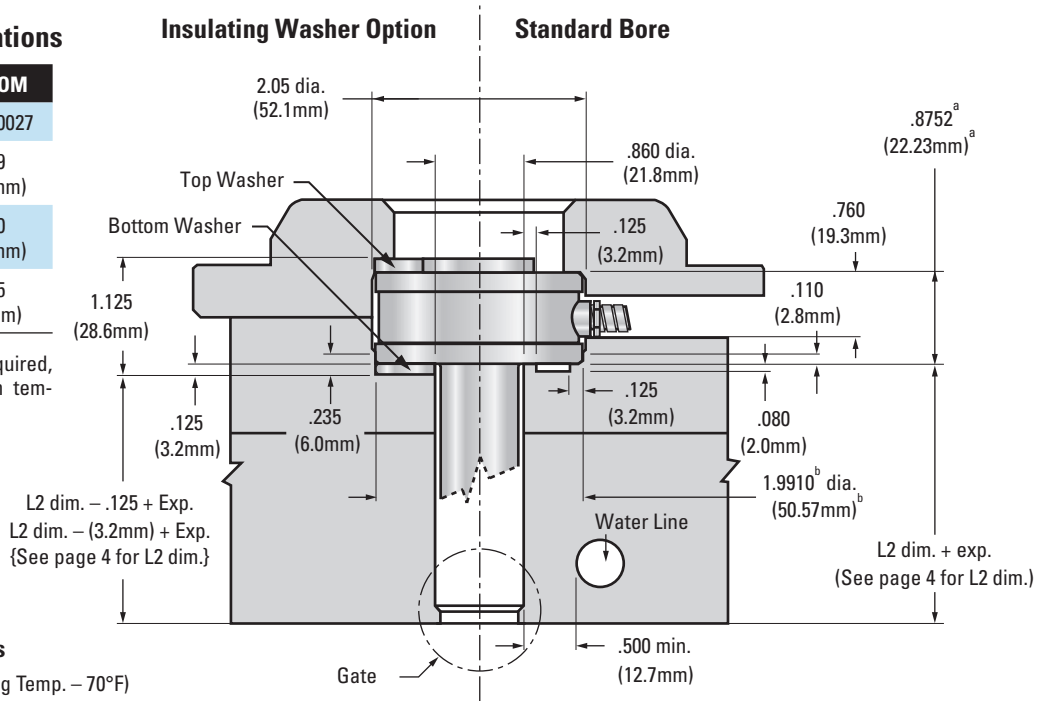

### Thermal Expansion (Exp.) Formulas

Exp. in = L2 in.  $\times 6.88 \times 10^{-6} \times$  (Processing Temp. - 70°F)

Exp. mm = L2 mm  $\times 13 \times 10^{-6} \times$  (Processing Temp. - 21°C)

Ref:  $10^{-6} = 0.000001$

All specifications are subject to change without notification.

### Sprue Gate

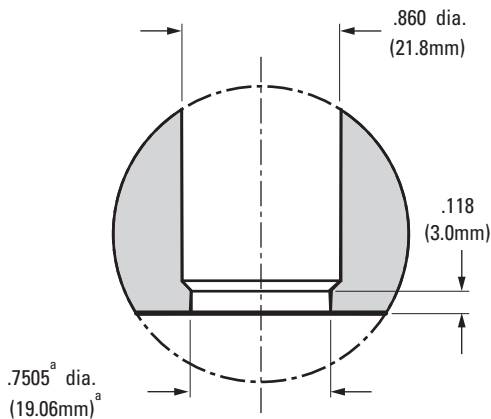

### Extra Stock Sprue Gate

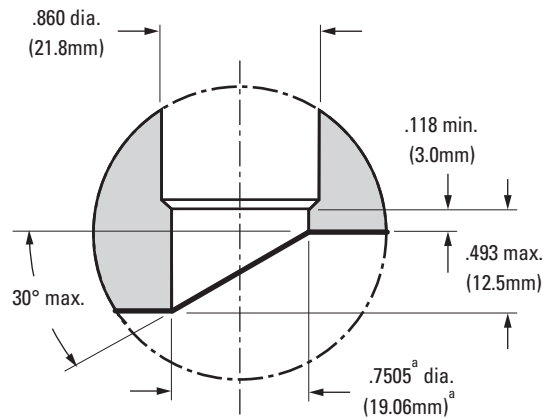

### Bore & Gate Tolerances

Tol. "a" Table	
in:	+ 0.0005
	- 0
mm:	+ 0.01
	- 0

Tol. "b" Table	
in:	+ 0.0010
	- 0
mm:	+ 0.02
	- 0

Dimensions are inches. Millimeters are in parentheses.

# Integrally Heated Sprue Bushings

## .750" SERIES

### Operating & Servicing Instructions

The Integrally Heated Sprue Bushing bodies are identical in design, but differ in length and head style. All Sprue Bushings feature an integrated heater; Type "J" thermocouple; 60" wrapped - 600 volt leads; right angle lead exit; and 6" stainless steel, square-lock armored cable.

#### Start-Up/Operating Procedures

If the temperature controller does not utilize "soft start" technology, set the controller to 200°F (93.3°C) in automatic mode or 10% in manual mode. Allow bushing to "soak" for 15 minutes before increasing to processing temperature. This step will allow the unit to dissipate potential moisture and prolong heater life.

#### Power Requirements

- 240 Volts AC – 15 amp fuse
- Grounding – Integrally Heated Bushings utilize the direct contact of the bushing, mold plates, and machine platens to establish a path for grounding.

#### \*WARNING\*

There must be a ground  $\equiv$  present between the mold "hot half" and the temperature control system or damage may occur to the bushing, thermocouple and/or temperature control system.

### Locating Ring Dimensions

ITEM NUMBER	L.R.D.
ML010012	3.990" (101.3mm)

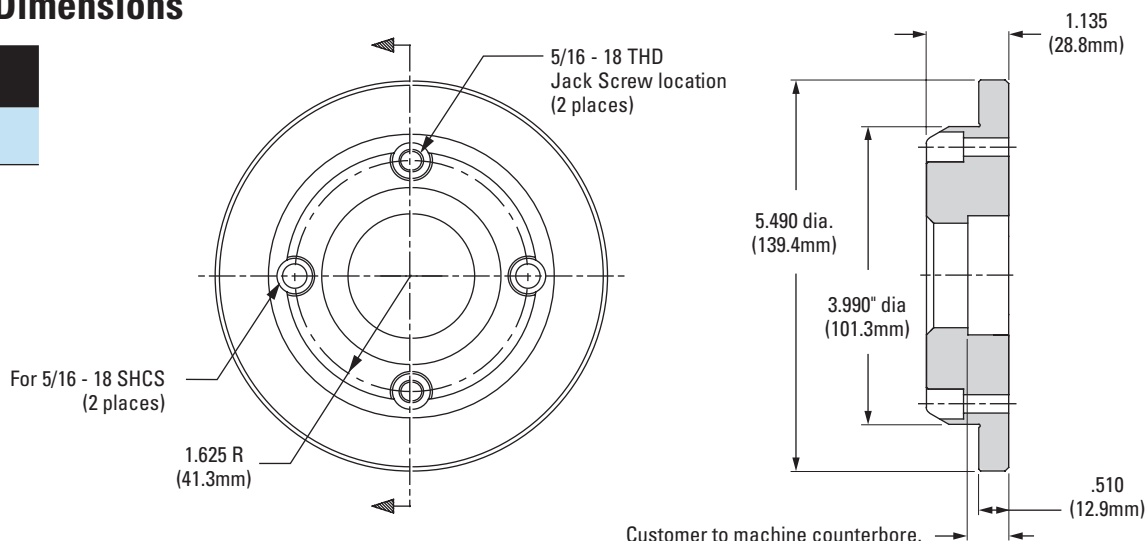

### Machining Options for Keying

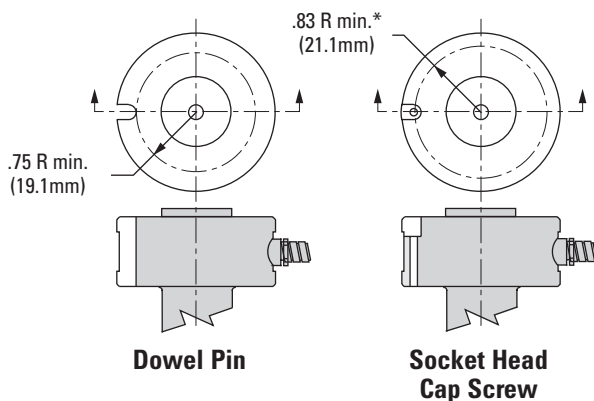

\*Centerline for #10 Screw

Dimensions are in inches; millimeters are in parentheses.

D-M-E, an essential resource to customers worldwide, offers the industry's broadest range of market-leading products, a global logistics infrastructure that ensures speed and accuracy, and a support organization with unsurpassed knowledge and expertise that assists customers when and where they need it. A complete line of mold bases, quick-change mold systems, mold components, mold making and molding supplies, hot runner systems, control systems, cold runner systems for elastomers, and technical services helps customers achieve success every step of the way.



**World Headquarters**

**D-M-E Company**

29111 Stephenson Highway  
 Madison Heights, MI 48071  
**800-626-6653** *toll-free tel*  
**248-398-6000** *tel*  
**888-808-4363** *toll-free fax*  
**www.dme.net** *web*  
**sales@dme.net** *e-mail*

**D-M-E of Canada, Ltd.**

6210 Northwest Drive  
 Mississauga, Ontario  
 Canada L4V 1J6  
**800-387-6600** *toll-free tel*  
**905-677-6370** *tel*  
**800-461-9965** *toll-free fax*  
**dme\_canada@dme.net** *e-mail*

**D-M-E Europe**

D-M-E Belgium C.V.B.A.  
 Industriepark Noord  
 B-2800 Mechelen  
 Belgium  
**32-15-215011** *tel*  
**32-15-218235** *fax*  
**sales@dmeeu.com** *e-mail*