

D-M-E Expandable Cavity System

Proven technology for
molding external threads,
grooves and undercuts

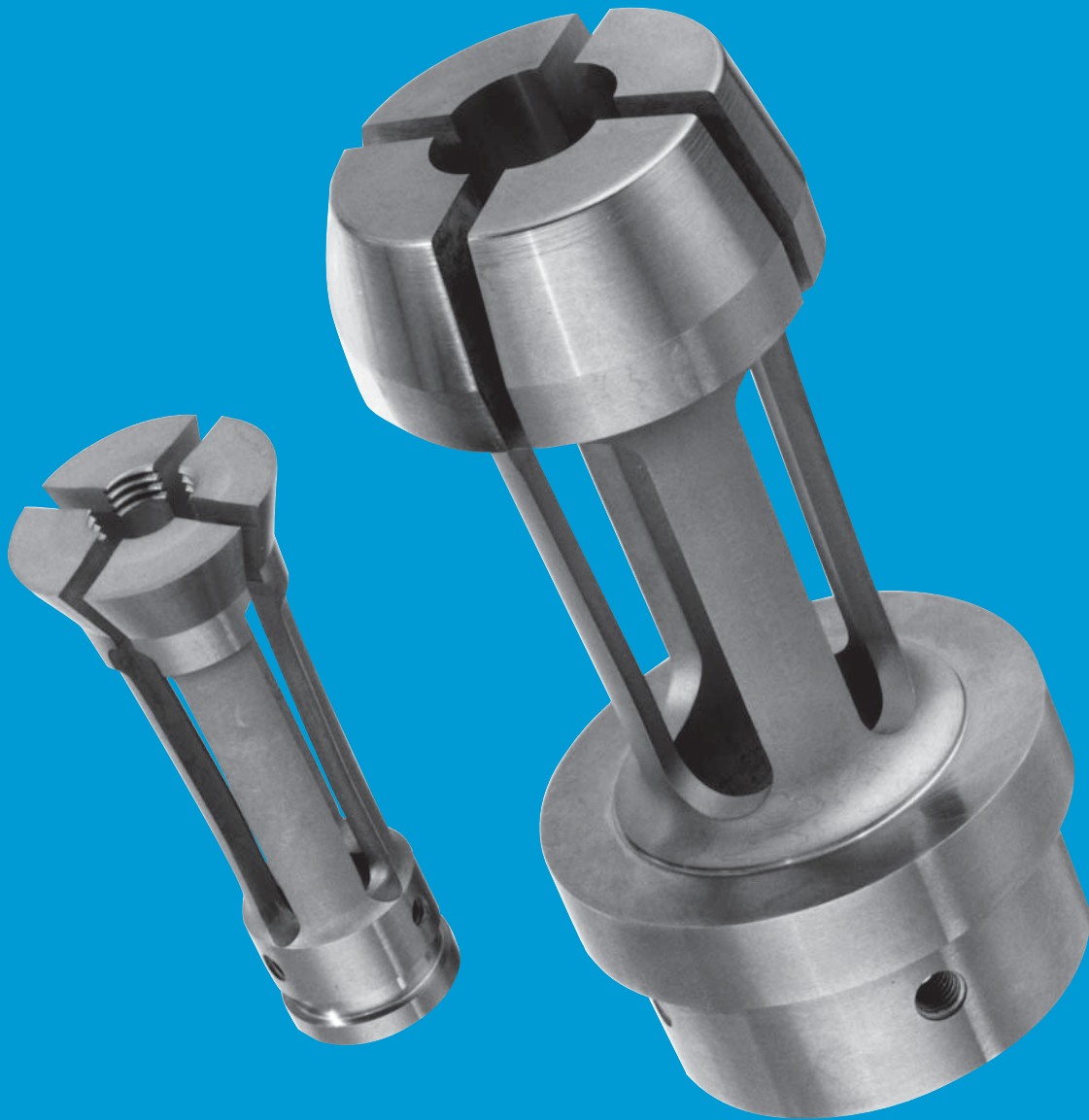

D-M-E Expandable Cavity System Benefits

Lowers development and processing costs

The Expandable Cavity saves money at every step — from initial tooling to processing to maintenance.

Intelligent engineering reduces or eliminates many costly factors such as complex design details, core slides and required mechanical components, added maintenance and replacement of high-wear items often found in traditional slide action molds.



The Expandable Cavity is maintained under compression during molding.

As the mold opens, segments are released automatically to the expanded position, and the part is released.

U.S. Patent Numbers
5,387,389 D 356,320

Broad range of benefits

Simple Design

The revolutionary design and engineering of the Expandable Cavity saves steps and solves problems that have complicated plastics molding for years. In addition to simplifying new tooling design, it can be retrofit to existing molds.

More reliable

Complete reliability of the Expandable Cavity is assured, not only by the simplicity of the design, but also by the use of superior materials and proven proprietary processing techniques. You can count on minimal downtime and higher productivity. The Expandable Cavity has been field tested over several million cycles.

More compact

Using the D-M-E Expandable Cavity allows you to design more cavities in each mold (see page K-52 for examples).

Speeds molding process

The Expandable Cavity concept eliminates the need for side-action mechanisms and the additional machining steps they require. Various part ejection methods can be employed.

Speeds development

The Expandable Cavity concept simplifies the engineering required to design and manufacture a new cavity. This means that your new products go into production in less time than was previously possible.

D-M-E Expandable Cavity System

Wide Variety of Applications

Typical parts molded with the Expandable Cavity System

The Expandable Cavity was developed for molding the external profile of circular and other parts with undercuts such as threads, dimples, and protrusions. Typical molded parts include:

- Bottle caps
- Plumbing supplies
- Snap O-ring caps
- Automotive parts
- Medical parts and packaging
- Hose couplings
- Industrial flanges and valves
- Electrical fixtures
- Cosmetic packaging

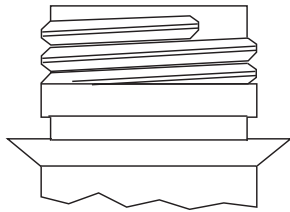

BOTTLE TOPS

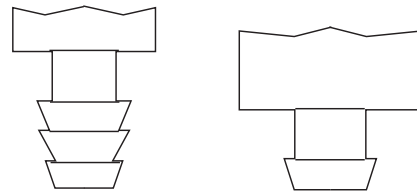

BARB CONNECTIONS

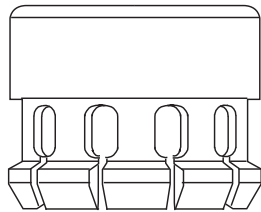

SNAP FIT COVERS/LENSES

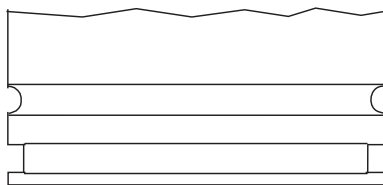

O-RING GROOVES

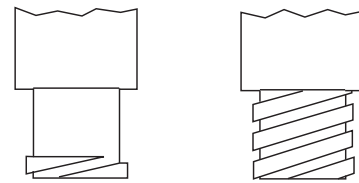

LUER CONNECTIONS

D-M-E Expandable Cavity System Components

Typical Expandable Cavity for
"A" Side Striker Insert

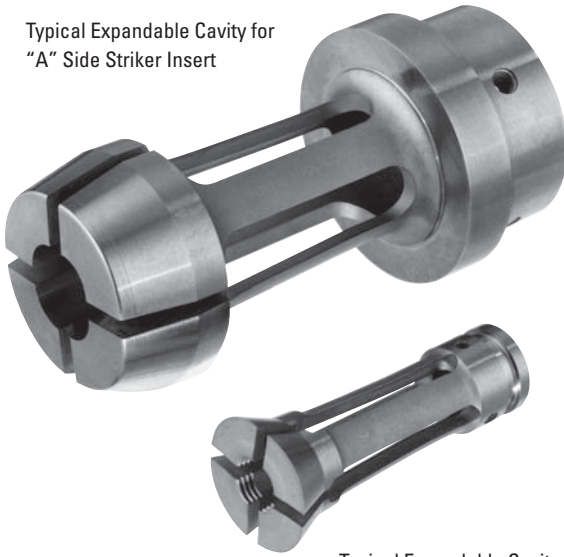

Typical Expandable Cavity for
"B" Side Striker Insert

General maintenance

After 100-200 initial shots, the Expandable Cavity should be rechecked to ensure proper mechanical function.

A routine maintenance program of your Expandable Cavity System is recommended after 50,000 to 100,000 cycles. Thoroughly degrease and demagnetize system components. Observe for signs of abnormal wear. A light lubricant such as a P.T.F.E. should then be applied to the Striker Insert, Center Pin and the Expandable Cavity. This will increase the life of the system components. Never use a heavy grease. Re-install Expandable Cavity System.

If this maintenance procedure is performed as described above, several million cycles are easily obtainable.

Expandable Cavity

The Expandable Cavity is typically made of A-2 tool steel, hardened to 54-58 Rockwell "C". The typical tool has four segments which expand radially away, under their own spring force, from the center axis of the tool. In the closed molding position, the precision fit between each segment permits flash-free molding.

Striker insert

The striker insert is made from different types of tool steel. It is typically hardened to 32-45 Rockwell "C" scale, depending on the application. The striker insert has a lower hardness than the Expandable Cavity to ensure the eventual wear will occur on the striker insert and not the detailed Expandable Cavity. Depending on the part configuration, the striker insert can be used in the "A" or "B" side of the mold (see Figs. 1 and 2 for details).

The striker insert must be closely fit to the Expandable Cavity to ensure that in the **mold closed** position the segments are completely sealed against one another. The tolerance on this fit must be held to ± 0.0005 inch to ensure flash-free molding.

Interchangeable center pin

The solid center mandrel is the most common type of center pin. It may have an inner cooling channel depending on its size. The center pin provides an internal shut-off with the Expandable Cavity.

Ejector sleeve

An ejector sleeve is commonly used to ensure part ejection from the cavity. The sleeve rides forward over the center pin, once the mold is opened and the cavity expanded. Many times the expansion needed is dependent on leaving clearance for the ejector sleeve.

Expansion limiter sleeve

If part design is such that it could tend to stick in the "A" side of the mold when the Expandable Cavity opens, an expansion limiter sleeve can be used. This sleeve will restrict expansion and retain the part until activation of a stripper plate allows additional expansion prior to part ejection (see Fig. 3).

D-M-E Expandable Cavity System Typical Applications

Fig. 1
With "A" Side Striker Insert

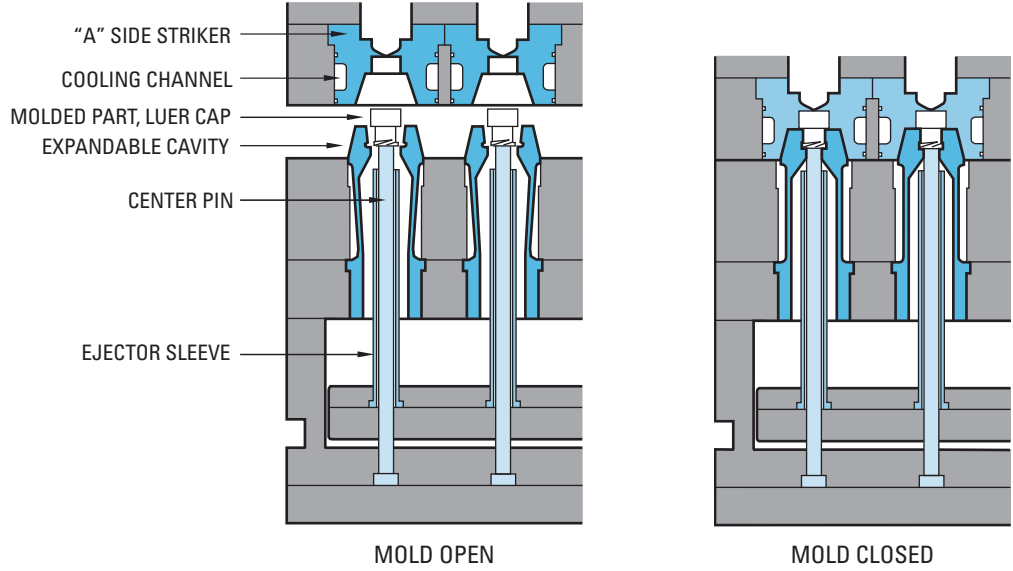

Fig. 2
With "B" Side Striker Insert

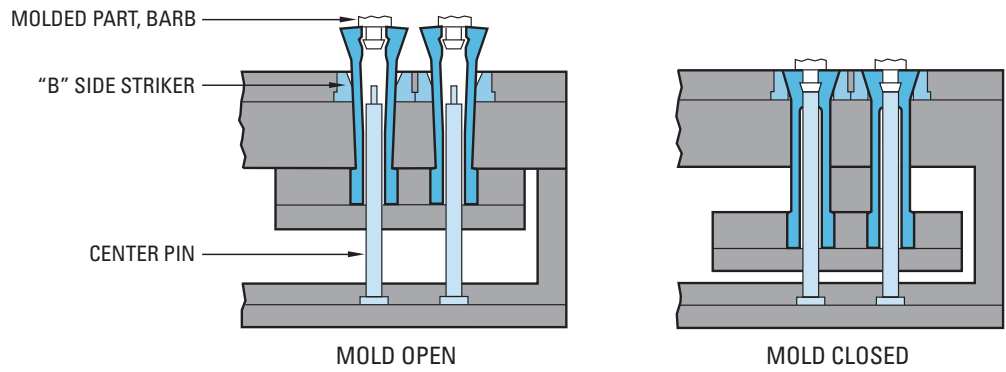
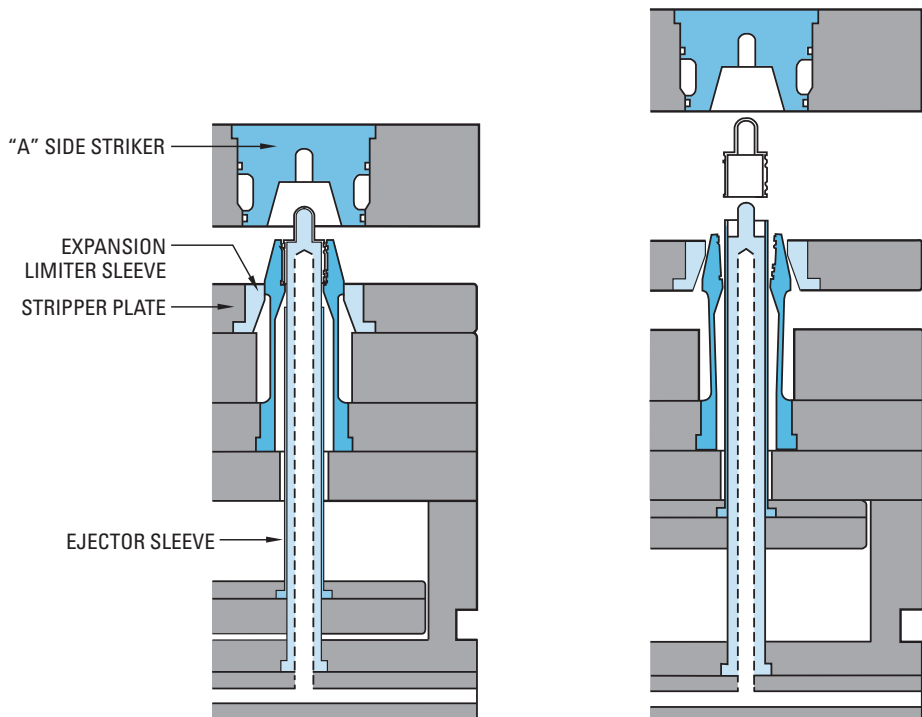

Fig. 3
With "A" Side Striker Insert and Expansion Limiter Sleeve



D-M-E Expandable Cavity System Plastic Part Design

The Expandable Cavity was designed to produce external details. All commonly used thermoplastic molding polymers, including filled materials and engineering polymers, have been successfully molded with the Expandable Cavity. When using a corrosive polymer such as PVC, the Expandable Cavity must be surface treated with a protective coating. To prevent loss of expansion properties in the Expandable Cavity, the surface treatment process should not exceed a temperature of 600° F.

Good plastic design practice should be observed to avoid such conditions as distortion, sink marks, etc. These problems and their solutions are identical to those found in conventional moldings.

All undercuts, protrusions, windows, etc. will typically include two to five degrees of draft. The bottom edge of the part must also have approximately two to five degrees of draft. Also, if molding is required on the top of the Expandable Cavity, two to five degrees of draft needs to be included. This is necessary because the segments flex radially away from the molding position in an arc. The draft allows the segments to expand freely.

NOTE: The amount of draft varies with tool design. Changes in tool design (length, body diameter, etc.) can minimize draft requirements.

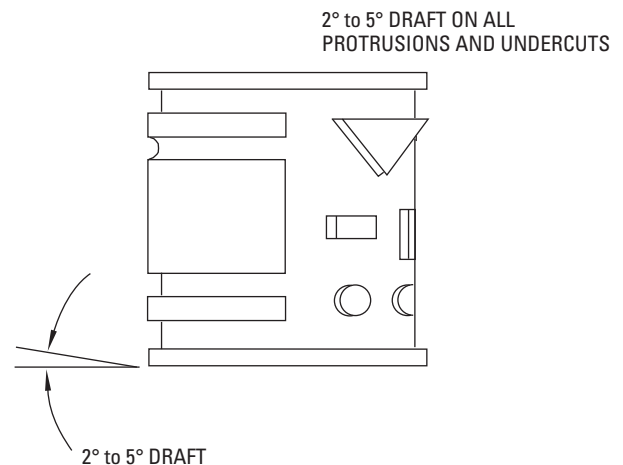
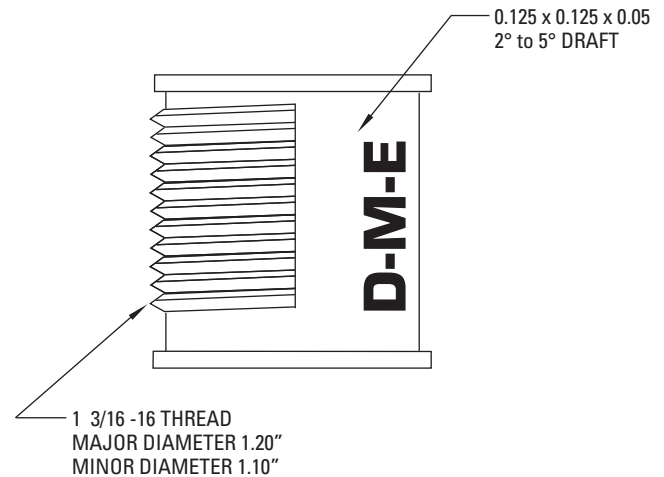
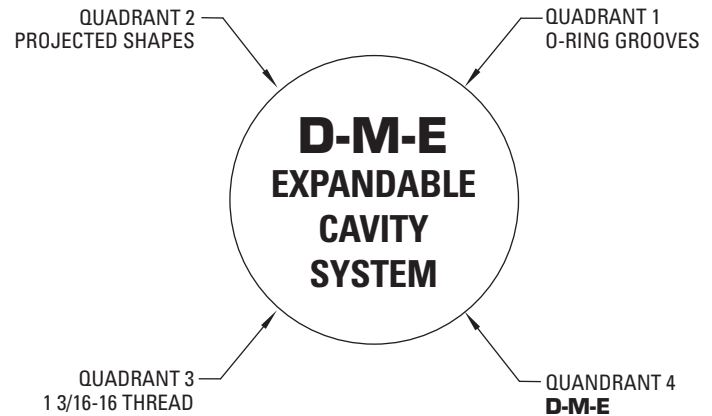

NOTE: Demo part has four (4) different quadrants of detail (call D-M-E for a sample).

D-M-E Expandable Cavity System

Expandable Cavity and Striker Insert Design

The Expandable Cavity can mold a full 360 degrees around. The most common configuration is four (4) segments that mold 90 degrees each. The Expandable Cavity can also be designed as asymmetrical, such as two segments that mold 90 degrees each and three segments that mold 60 degrees each. (Contact D-M-E Applications Engineering for details.) The amount of expansion varies according to the part requirements and clearances needed.

The general calculations for total expansion necessary are:

1. Calculate the critical expansion per side

The critical expansion (CE) needed to release the undercut is not the radial difference between major diameter (D) and minor diameter (d). For a typical four segment Expandable Cavity, the formula for calculating critical expansion is (see Fig. 4):

$$CE = \frac{\sqrt{D^2 - (d^2/2)}}{2} - \frac{\sqrt{2} \times d}{4}$$

2. Calculate the loss of expansion

$$\text{Loss of expansion} = \text{molding length} \times .050\text{in}$$

The loss of expansion is the amount of expansion the tool loses as you move back from the cavity's face. This is due to the fact that the segments expand radially outward from fixed points on the common base. The outward bend of a typical segment is about 2 to 3 degrees. The tool typically loses 0.050 inch per inch as you move into the Expandable Cavity from the tool's face (see Fig. 5).

3. Calculate the total expansion

$$\begin{aligned} \text{Total expansion} &= \text{critical expansion per side} \\ &+ \text{loss of expansion} + 0.005 \text{ clearance} \end{aligned}$$

When the mold is closed, the exterior of the Expandable Cavity must be supported by the Striker Insert at least 7/8 of the molding length plus the shut-off, to ensure no flash conditions. Allow for 0.200 inch of shut-off length below the molding length — any more is excessive (see Fig. 6).

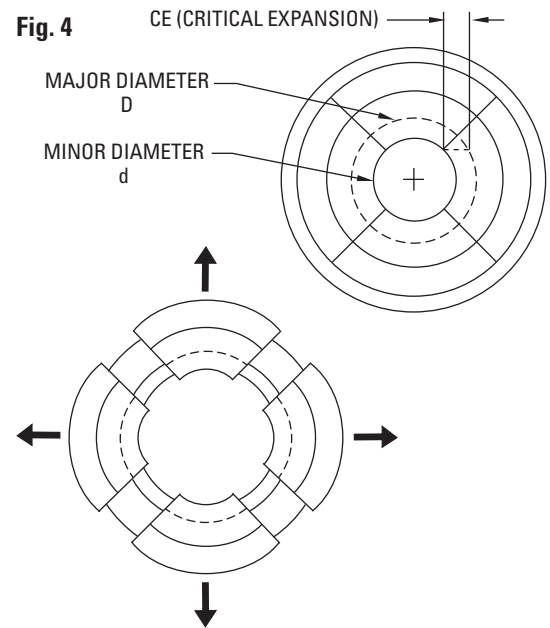

Fig. 4

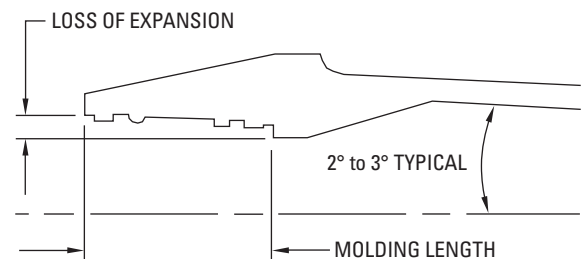
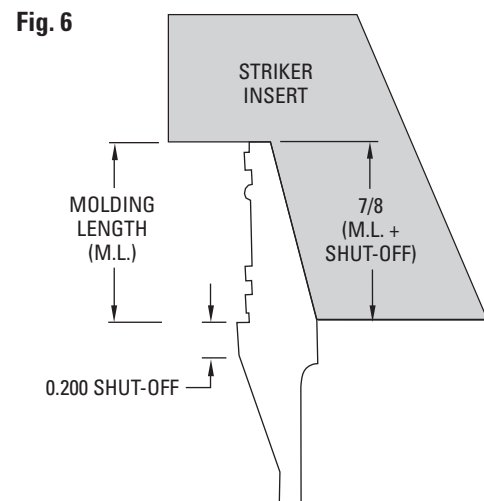
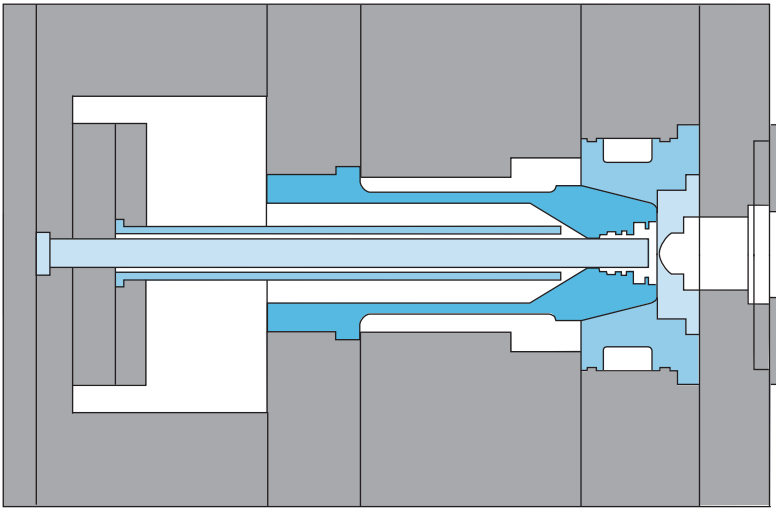

Fig. 5



D-M-E Expandable Cavity System Typical Operating Sequence

Mold Closed



Mold Open, Cavity Expanded

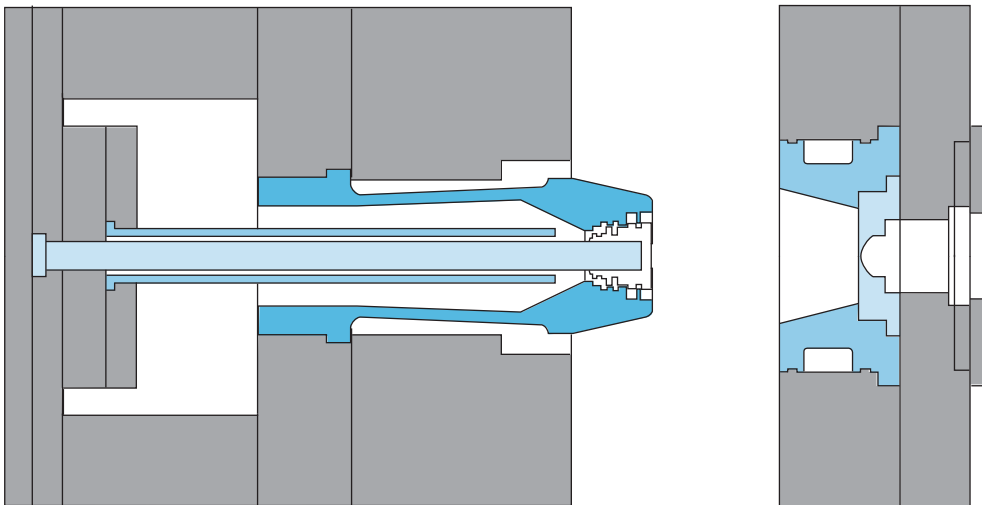

Ejector Forward, Part Ejected

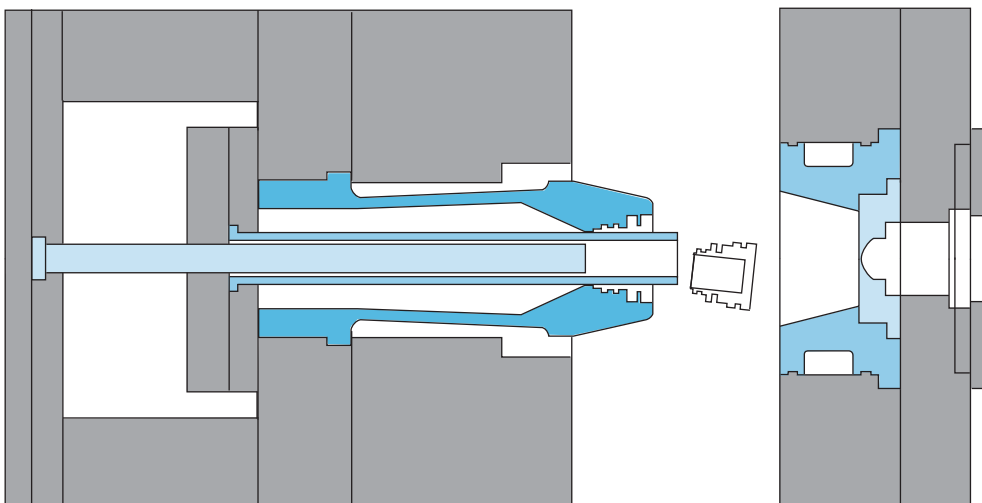

D-M-E Expandable Cavity System Typical Mold Layouts

Go from this ...

Mold Layout with Conventional Slide Mold

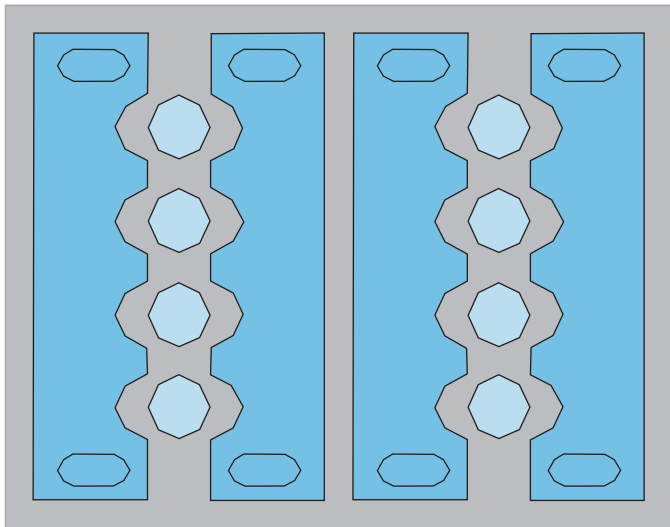

to this ...

Reduced Mold Size with Expandable Cavity

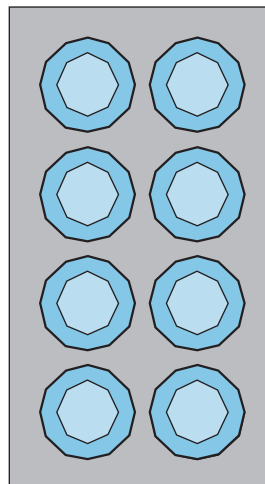

Radial Mold Layout with Expandable Cavity

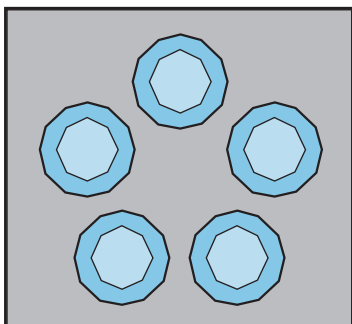

Nest Mold Layout with Expandable Cavity

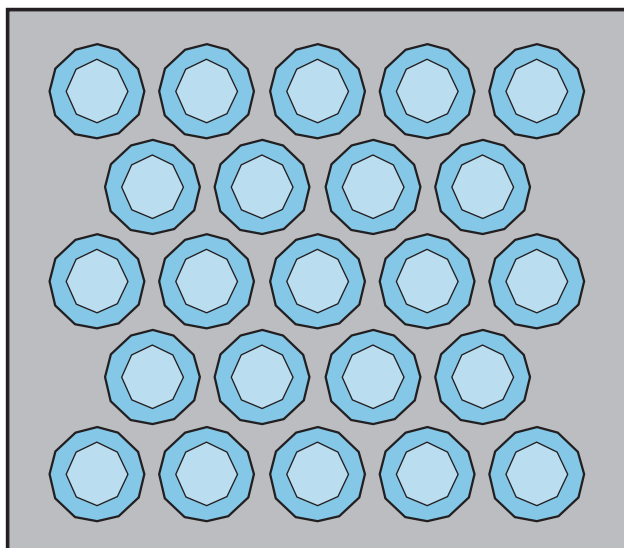

D-M-E Expandable Cavity System

The Possibilities are Almost Limitless

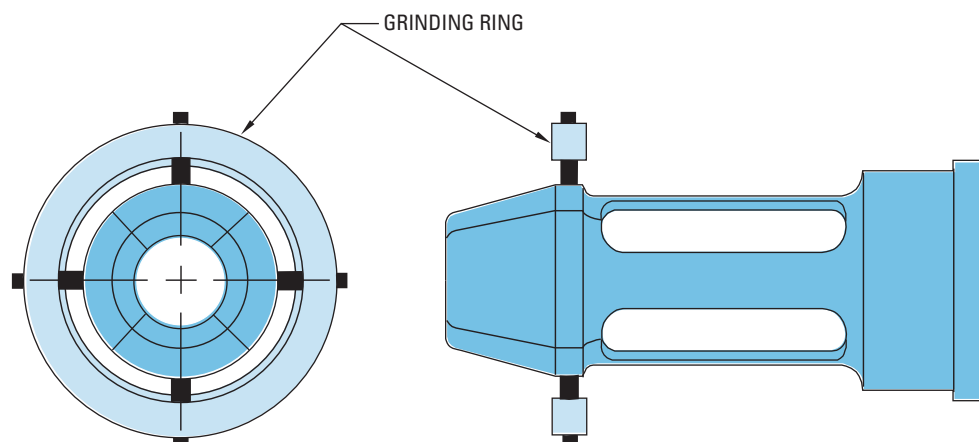

- Size Range: The Expandable Cavity is typically designed for parts with outside dimensions of 1/32 to 3 inches, but more custom designs are also available to suit your overall part size or undercut requirements
- Can be designed for retrofit to existing molds
- Can be designed for use in combination with D-M-E Collapsible Cores, Collapsible Mini-Cores, unscrewing cores or straight pull outs for interior of part
- Can be designed in inch or metric sizes

The Expandable Cavity System may be subject to restrictions in its use for the molding of plastic tamper-indication closures in threaded caps under U.S. Patent No. 5,281,385 of Sunbeam Plastics Corporation. Roehr Tool disclaims any damages or responsibility for the use of its core when used in the method of such patent.

Detailing

Most Expandable Cavity details are usually ground or EDM'd. It is important when grinding to flood tool with suitable coolant for hardened tool steels. Do not grind with a loaded wheel (dress wheel frequently). The wheel must be of a soft grade (60J, 46J, etc.). When grinding make sure the Expandable Cavity is completely closed in a true circle by using the grinding ring supplied, as shown here.

After all finish grinding, polishing and EDM'ing work, be sure to demagnetize the Expandable Cavity to prevent adhesion of any metal particles that might find their way into the cavity during molding.

NOTE: D-M-E does not provide the part configuration detailing or machining. We can direct you to an appropriate source for this service if required.

How to order

The Expandable Cavity is designed and constructed based on part configuration and mold design requirements. For a quotation, copy and fill out the Quote Request Form on the facing page and mail or fax to the address or fax number shown on the form. If you also include a part print and/or mold design, D-M-E can assist you in determining the feasibility of molding with the Expandable Cavity and review your overall mold design.

D-M-E Expandable Cavity System

Applications Engineering Quote Request Form

D-M-E COMPANY
29111 Stephenson Highway
Madison Heights, MI 48071

Date: / /

FAX TO: (248) 544-5707

Company _____ End User _____

Address _____ Address _____

Phone _____ Phone _____

FAX _____ FAX _____

FAX _____ FAX _____

Contact _____ Contact _____

Acct. No. _____ Acct. No. _____

Terr. No. _____ Terr. No. _____

Expandable Cavity Requirements

I. POLYMER SPECIFICATIONS:

A. What is the material to be molded? _____

B. What is the process temperature? _____ Filled Unfilled Glass Mineral

II. DIMENSIONS OF EXPANDABLE CAVITY: (Part print is required)

A. Specify largest diameter to be molded _____

B. Specify smallest diameter to be molded _____

C. Specify major diameter of undercut or thread _____

D. Specify minor diameter of undercut or thread _____

III. MOLDED PART LENGTH:

A. Molding Length: _____ (Within the Expandable Cavity)

B. Mold Shut-off: .200 (Shut-off land below part)

IV. EXPANSION REQUIREMENTS: (See explanation on page K-50)

A. Critical Expansion per side: _____

B. Loss of expansion (.050in/in): _____
Multiply molding length (Distance from top of Expandable Cavity to bottom of last undercut) by .050in

C. Clearance (Air) between plastic and steel upon expansion: .005

V. MOLD LAYOUT

A. Distance from gate (center to center): _____

B. Number of cavities: _____

Retrofit New Mold

World Headquarters

D-M-E Company

29111 Stephenson Highway
Madison Heights, MI 48071
800-626-6653 *toll-free tel*
248-398-6000 *tel*
888-808-4363 *toll-free fax*
www.dme.net *web*
appl_eng@dme.net *e-mail*

D-M-E of Canada, Ltd.

6210 Northwest Drive
Mississauga, Ontario
Canada L4V 1J6
800-387-6600 *toll-free tel*
905-677-6370 *tel*
800-461-9965 *toll-free fax*
dme_canada@dme.net *e-mail*

D-M-E Europe

D-M-E Belgium C.V.B.A.
Industriepark Noord
B-2800 Mechelen
Belgium
32-15-215011 *tel*
32-15-218235 *fax*
sales@dmeeu.com *e-mail*

