

500 SERIES

POLIMAX LINE

COMMODITY HOT SPRUE BUSHING PACKING SLIP

Drawing No. ME-060001-0549(D) Catalog No. BDP-10-9999



VIEW A (VIEW OF BUSHING HEAD INSTALLATION HOLE AND HEAD HEATER CLEARANCE SLOT FROM STATIONARY PLATEN)

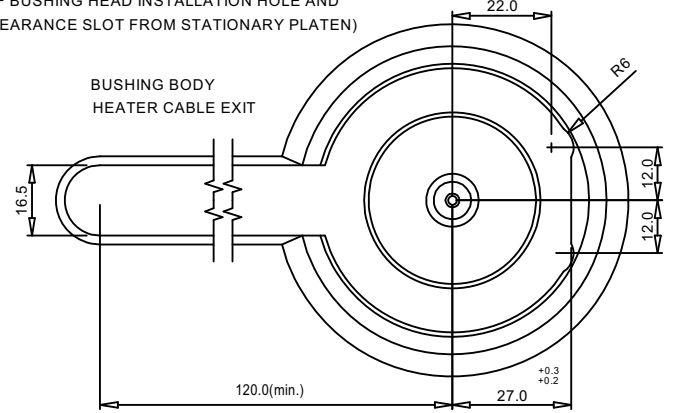
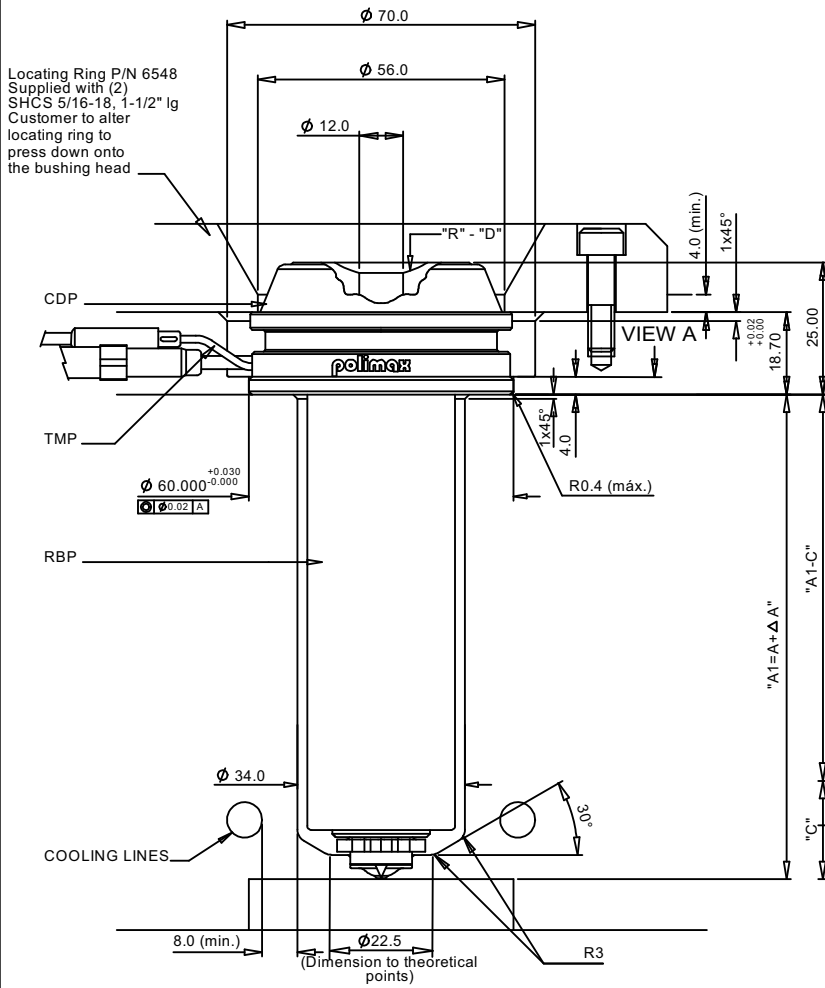

CODE FOR DETAIL	DIMENSION "R"	DIMENSION "D"
...-R000	0	
...-R155	15.5	
...-R400	40.0	
...-R050	1/2"	
...-R075	3/4"	
...-D090		90°

Ex: BDP10055-R400

SPHERICAL RADIUS 40mm

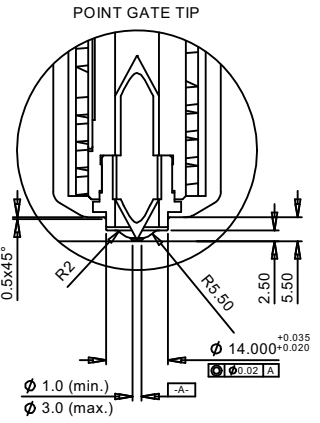
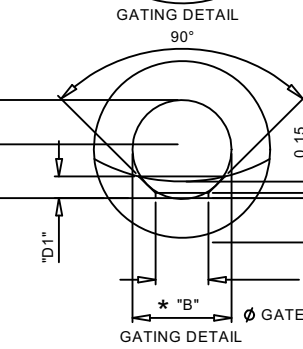
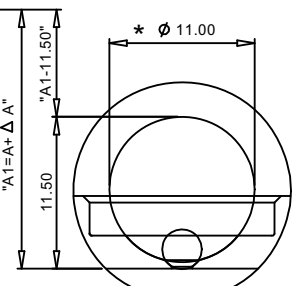

Nozzle Thermal Expansion "ΔA" = A x 0.0000115 x (Setpoint °C - 20°C)
 Nozzle Thermal Expansion "ΔA" = A x 0.0000064 x (Setpoint °F - 68°F)

BUSHING CODE	DIMENSION "A"	SPECIFICATION FOR BUSHING COMPONENTS			
		BODY OF BUSHING	BODY HEATER	POWER	THERMOCOUPLE
BDP10055-R...	55.00	CDP10055-R...	RBP10056	500W	TMP01080
BDP10067-R...	67.50	CDP10067-R...	RBP10069	690W	TMP01100
BDP10080-R...	80.00	CDP10080-R...	RBP10081	760W	TMP01120
BDP10092-R...	92.50	CDP10092-R...	RBP10094	760W	TMP01140
BDP10105-R...	105.00	CDP10105-R...	RBP10107	760W	TMP01160
BDP10130-R...	130.00	CDP10130-R...	RBP10131	850W	TMP01180
BDP10155-R...	155.00	CDP10155-R...	RBP10158	1100W	TMP01200
BDP10180-R...	180.00	CDP10180-R...	RBP10183	1300W	TMP01220

GATE DIAMETER	DIMENSION "B"	DIMENSION "C"	DIMENSION "D1"
φ1.0	φ2.00	2.06	0.58
φ1.2		1.96	0.60
φ1.4		1.86	0.63
φ1.6	φ3.00	2.97	0.66
φ1.8		2.87	0.69
φ2.0		2.77	0.73
φ2.2	φ4.00	3.88	0.78
φ2.4		3.78	0.83
φ2.6		3.68	0.89
φ2.8	φ5.00	4.78	0.96
φ3.0		4.68	1.05

NOTE: 1) MAXIMUM OPERATING PRESSURE IN BUSHING 138 MPa (20,000 PSI)
 2) MAXIMUM OPERATING TEMPERATURE OF BUSHING 288°C (550°F)
 3) WATTS SHOWN BASED ON 230 V
 4) FOR EXTRA STOCK TIPS, CUSTOMER MUST MODIFY AND ADD RELIEF, SUCH THAT AVERAGE LAND CONTACT IS 3.00mm.
 5) UNLESS OTHERWISE STATED, DIMENSIONS SHOWN ARE IN MILLIMETERS.

* THE "B" AND 11.00 DIAMETER DIMENSIONS ARE CORRECT BALL GAGES TO BE USED FOR CHECKING THE "A1-C" AND "A1-11.50" DIMENSIONS.

TIP OPTIONS

SPRUE GATE TIP

RING GATE TIP

SPRUE GATE EXTRA STOCK TIP

RING GATE EXTRA STOCK TIP

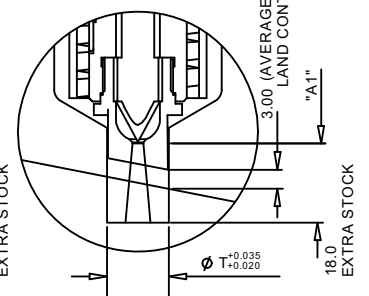
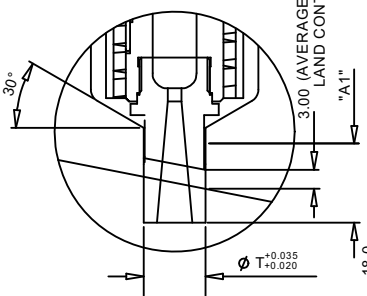
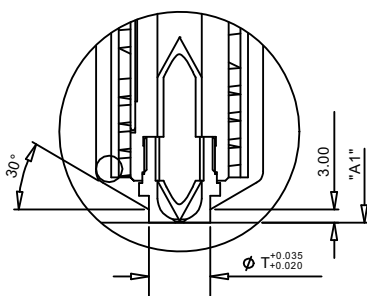
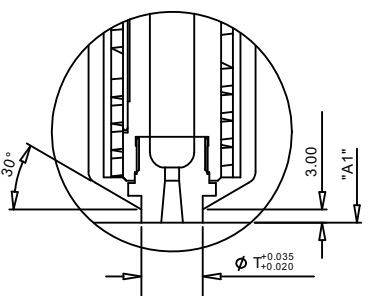

500 SERIES

POLIMAX LINE

COMMODITY HOT SPRUE BUSHING PACKING SLIP

Drawing No. ME-060001-0549(D) Catalog No. BDP-10-9999



READ USER INSTRUCTIONS BEFORE SERVICING OR OPERATING

IMPORTANT SAFETY INFORMATION

A hot-runner system includes electrical elements and may contain molten plastic at elevated temperature and pressure. To avoid injury, exercise caution by reading these instructions before servicing or operating the system.

These instructions must be passed on to the end user where they should be read before using this product. Failure to do so can result in serious injury or death.



Failure to comply will result in serious injury or death:

ELECTRICAL HAZARDS

Improper voltages or grounding can result in electrical shock. Use only with proper voltage and a proper earth ground.

To avoid electrical shock, do not operate product when wet.

Do not operate this equipment with covers or panels removed.

To avoid electrical shock, turn off main power disconnect and lock out / tag out before servicing this device.



Failure to comply could result in serious injury:

STORED ENERGY AND HIGH TEMPERATURE HAZARDS

This product maintains molten plastic at high pressure. Use caution when operating and servicing the system.

Physical contact with molten plastic may result in severe burns. Proper protective equipment, including eye protection, must be worn.

This product has heated surfaces. Use caution when operating and servicing the system to avoid severe burns. Proper protective equipment should be worn.

OPERATING PROCEDURE:

The bushings are supplied with a Square (flat) Coil Heater with a jacket that fits around the heater. The heater has an internal J type thermocouple. An external J type thermocouple is also provided as a spare.

It is recommended to use a DME Closed Loop Temperature Controller for optimum temperature control. It is essential to use controller with the proper Voltage and Wattage capabilities.

DISASSEMBLY PROCEDURE:

For tip and/or needle removal, proceed with steps: 1 thru 10

For bushing heater removal, proceed with steps: 1 thru 5 and 11 thru 15

For external thermocouple removal, proceed with steps: 1 thru 5 and 11 thru 17

- 1) Unplug the two (2) bushing heaters from controller.
- 2) Remove all waterlines from mold.
- 3) Remove mold from injection molding machine.
- 4) Remove bushing from mold base.
- 5) Place head of bushing in a vise using "V" blocks, then secure the head firmly. (Heater leads should be upright.)
- 6) Attach a (EARTH) ground to the vise.
- 7) Plug in bushing heater and thermocouple into controller.
- 8) Turn on controller and set at processing temperature.
- 9) Wait 5 minutes after processing temperature has been achieved, turn off and unplug heater and thermocouple.
- 10) Using a 17mm, 12 point deep well socket to remove tip counter clockwise from bushing.
- 11) Slide Heater Jacket Removal Tool (HJRT) tip end into slot in jacket of bushing square coil heater.
- 12) Jacket slot to fit into HJRT "V" grooves.
- 13) Squeeze HJRT handles together to open jacket up and slide jacket off heater.
- 14) Remove HJRT from jacket.
- 15) Slide square coil heater off of bushing shaft.
- 16) Lift external thermocouple from slot in bushing shaft.
- 17) Remove bushing from vise.

ASSEMBLY PROCEDURE:

For external thermocouple assembly, proceed with steps: 1 thru 9 and 13 thru 20

For bushing heater assembly, proceed with steps: 2, 4 thru 9 and 13 thru 20

For tip assembly, proceed with steps: 1, 2 and 10 thru 20

- 1) Bushing and tip and/or needle must be clean of all material.
- 2) Place head of bushing in vise using "V" blocks, then secure the head firmly. (Slot in bushing head should face upright)
- 3) Place external thermocouple in bushing shaft slot.
- 4) Slide square coil heater onto bushing shaft, centering leads in slot of bushing head.
- 5) Slide HJRT into jacket slot, opposite end of large slot.
- 6) Jacket slot to fit into HJRT "V" grooves.
- 7) Squeeze HJRT handle together to open jacket up and slide jacket over heater.
- 8) Align larger slot of jacket over the heater leads.
- 9) Remove HJRT from jacket.
- 10) Apply "C5A" anti-seize compound on threads of tip.
- 11) Thread tip and/or needle into bushing shaft. Tighten and untighten two or three times making sure there is good contact between tip and bushing.
- 12) Torque tip and/or needle into bushing at 75Nm, using a 17mm, 12 point deep well socket.
- 13) Remove bushing from vise.
- 14) Check heaters and thermocouple with OHM meter for correct resistance.
- 15) Assembly bushing into mold.
- 16) Assembly mold into Injection Molding Machine.
- 17) Attach all waterlines to mold.
- 18) Plug bushing heaters and thermocouples into controller.
- 19) Turn on controllers using operating procedure as specified.
- 20) Wait a minimum of 5 minutes after set point has been achieved for sufficient heat to transfer into bushing before molding.

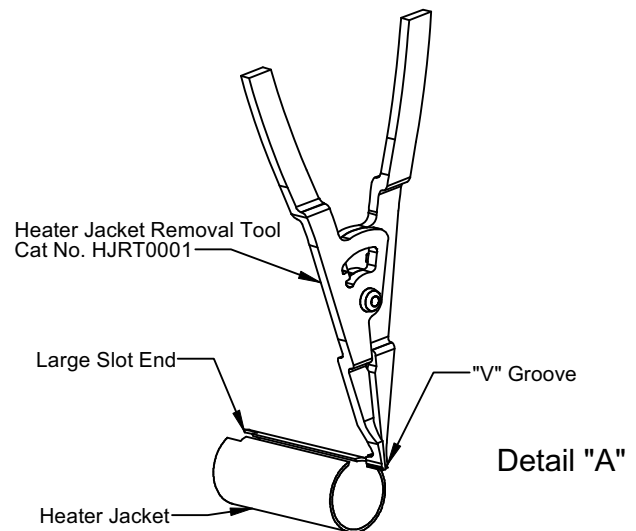

WIRE-UP NOTES

- 1) Heater wattages based on 230 V.
- 2) Heater power lead colors can be either:
 - a) Grey and Black
 - b) Grey and Purple
 - c) Black (both leads)
 - d) Tan with Red tracer (both leads)
- 3) Heater ground wire lead color can be either:
 - a) Yellow with Green Tracer
 - b) Green
- 4) System comes with external thermocouple, and heater has internal spare thermocouple. Use external thermocouple for normal operation.
- 5) Thermocouple lead wire color code combination can be either:
 - a) Black (+, positive), White (-, negative)
 - b) White (+, positive), Red (-, negative)
 - c) Red (+, positive), Blue (-, negative)

Step Start[®], Smart Start[®], Integrity[®] and DME[®] are all registered trademark of DME Company

Polimax[®] is a registered trademark of Polimold[™] Industrial S.A.